

Product Information



Xclude™ Contamination Exclusion

Xclude™ Standard Breather

Basic protection from moisture and particulate contamination in lubricant and equipment

Typical Industries

- Power generation
- Mining
- Aviation
- Storage
- Manufacturing
- Petrochemical

Applications

- Totes
- Transformers
- Storage tanks
- Hydraulics





Xclude™ Standard Breather

By the Numbers

1—Domed Cap

Allows for better washdown runoff.

2—Integrated Nylon Standpipe

Provides excellent vibration resistance and dissipates impact throughout the unit, eliminating weak points. It also allows even airflow distribution throughout the unit, eliminating inaccurate readings of desiccant saturation.

3—External Ribs on Shell

Create greater durability and grip when installing or replacing breather.

4—Integrated Drip Ring

Prevents water from entering vent holes.

5—Threaded Mounting

Easily replaces standard filler/breather cap with multi-fit connection or one of several adapters.

6—Air Vents

Individual air intakes are opened based on flow requirements of the system. Plugs protect unit during shipping and storage.

7—Foam Filter Pad

Captures any oil mist and disperses incoming air evenly over filtration and drying areas.

8—Polyester Filter Element

Removes airborne contamination to 3-micron absolute. Unique loops allow particles to release during system exhalation, helping to increase breather life.

9—Enhanced Seal

Eliminates potential for airflow bypass.



How It Works

This breather unit replaces the standard dust cap or OEM breather cap on equipment. As air is drawn into equipment through the breather, the layered filter elements remove particulate while the desiccant beads strip harmful moisture.

While in service or during shutdown, the desiccant beads attract moisture from inside the equipment reservoir, actively drying the equipment.



Materials & Components

- Housing: Polycarbonate, nylon, 6/6 30% glass filled, polypropylene
- Seals (LEXS375-13, LEXS375-28): Buna-N, EPDM, PVC
- Seals (LEXS1-66, LEXS1-122, LEXS1-188): Buna-N, PVC
- Filter media: Polyurethane, polyester
- Hydrophilic media: Silica gel

Chemical Compatibility

- Compatible with all mineral oils, most synthetic oils and diesel. Contact your local consultant for chemical compatibility inquiries.

Filter Efficiency

- 3 μ absolute ($\beta_{3\geq 200}$)

Certificates and Approvals

- Upon request

Recommended Temperature Range

- -20°F to 200°F (-29°C to 93°C)

Breather Specifications

Model	Amount of Desiccant (lb / kg)	Adsorption Capacity (fl oz / ml)	Air Flow Rate (cfm @ 1 Psid)	Air Flow Rate (gpm / lpm)	Max Suction & Return Rate (gpm / lpm)	Gearbox & Storage Tank Reservoir Size (gallons / liters)	Hydraulic Reservoir Size (gallons / liters)
LEXS375-13	.1 / .1	.8 / 23	5	34 / 129	34 / 129	15 / 57	2 / 8
LEXS375-28	.3 / .1	1.7 / 50	4	31 / 118	31 / 118	35 / 132	5 / 19
LEXS1-66	.8 / .4	4.9 / 146	16	120 / 453	120 / 453	200 / 757	60 / 227
LEXS1-122	1.4 / .6	8.7 / 257	16	120 / 453	120 / 453	350 / 1,325	100 / 379
LEXS1-188	2 / .9	12.4 / 365	16	120 / 453	120 / 453	500 / 1,893	200 / 757

Breather Sizing / Air Flow Guidelines

Note: These are general guidelines for sizing; other considerations, such as: humidity level, frequency of air flow, ambient temperatures, and chemical compatibility are very important in sizing a breather properly. Larger applications and special circumstances require thorough analysis. Please contact LE for assistance in breather sizing for your application.

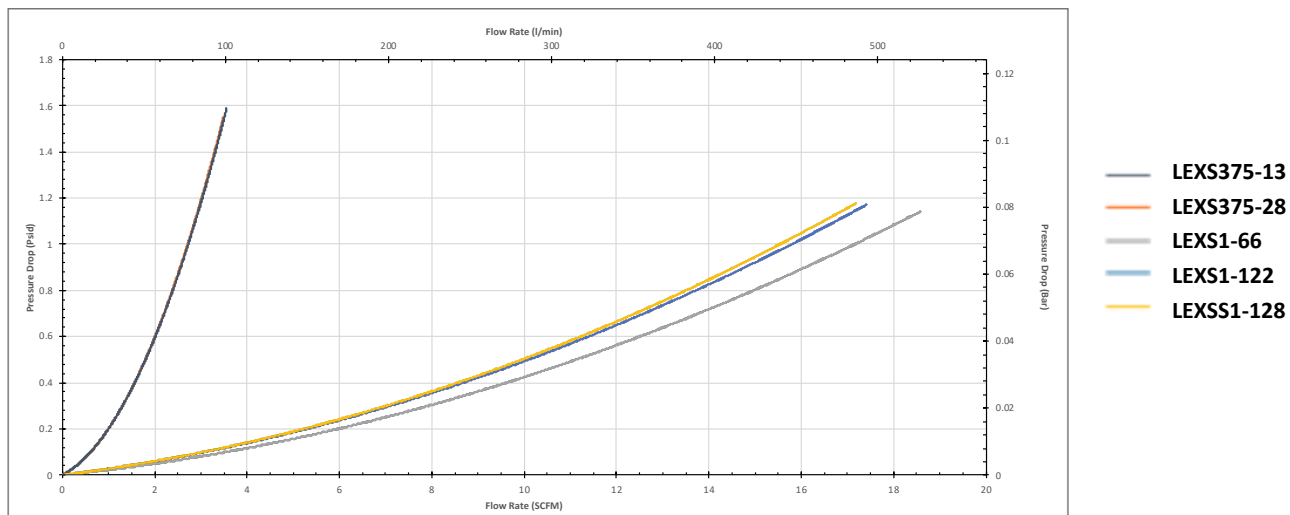



Additional Specs

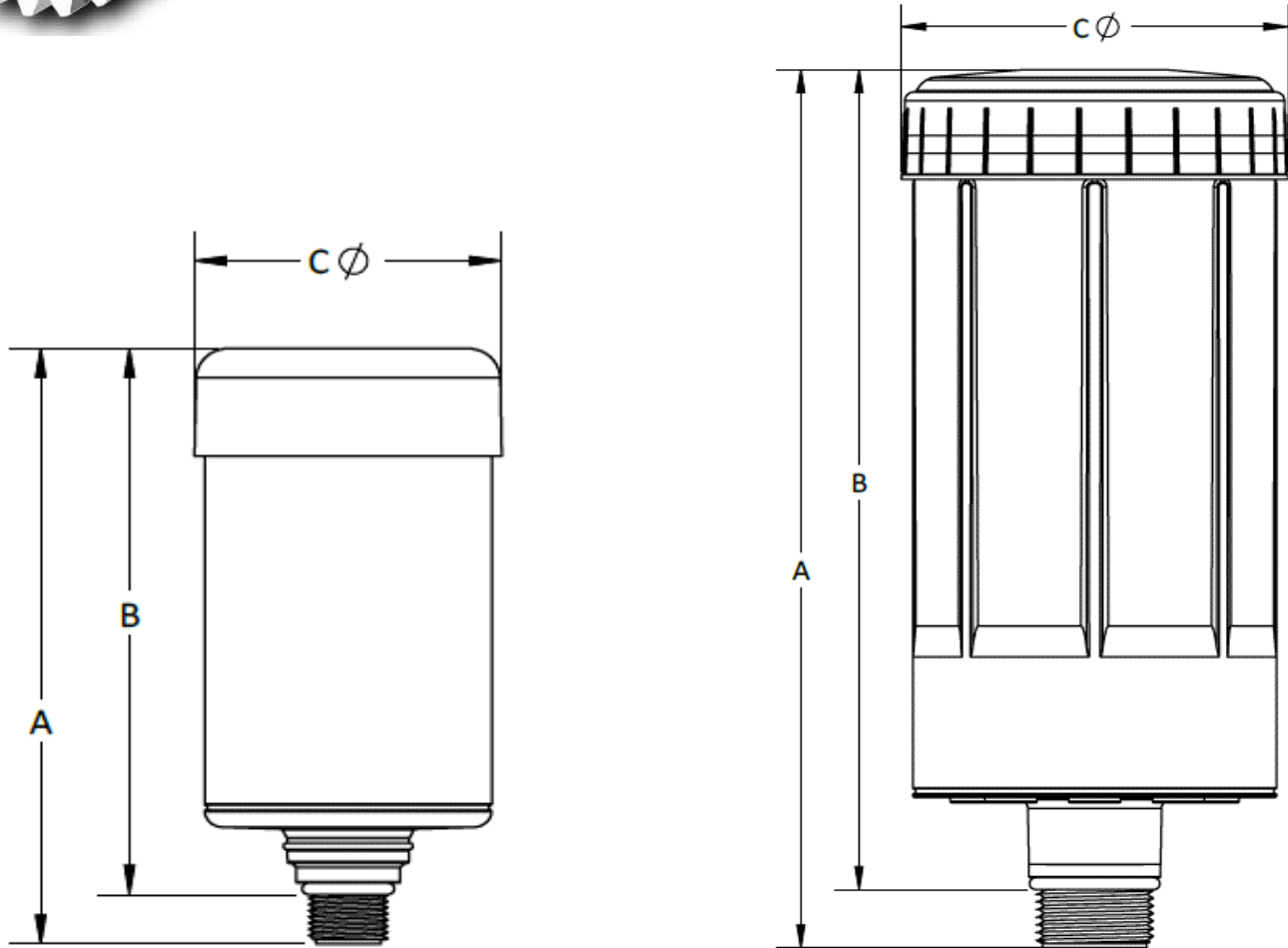

Breather Dimensions

Model	Style	Thread Size (Multi-Fit Male)	A (inch / mm)	B (inch / mm)	C (inch / mm)
LEXS375-13	miniature	3/8" with O-Ring Seal, Compatible with: 3/8" NPT; 3/8" BSPT; 3/8" BSPP	3.87 / 98	3.43 / 87	2.52 / 64
LEXS375-28			5.4 / 136	4.9 / 125	2.52 / 64
LEXS1-66	standard	1" with O-Ring Seal, Compatible with: 1" NPT; 1" NPSM; 1" BSPT; 1" BSPP	6.0 / 152	5.33 / 135	4.1 / 104
LEXS1-122			8.0 / 203	7.33 / 186	4.1 / 104
LEXS1-188			10.0 / 254	9.33 / 237	4.1 / 104

Xclude™ is a trademark of Lubrication Engineers, Inc.

LEX_SDFLY_101 5-15, rev. 2-20