

# Product Information



## Xclude™ Contamination Exclusion

---

### Xclude™ Extended Series Breather

*High airflow, long-lasting desiccant breathers with check-valve technology are ideal for tank farms and large applications.*

#### Typical Industries

- Wind energy
- Storage
- Pulp & paper
- Mining
- Aviation
- Manufacturing
- Petrochemical

#### Applications

- Storage tanks
- Wind turbines
- Large gearboxes
- Remote applications





## How It Works

As wet, contaminated air is drawn through the unit, multiple 3-micron polyester filter elements remove solid particulate, and the color-indicating silica gel extracts moisture. When air is expelled from the container, the top foam pad prevents oil mist from contacting silica gel or entering the atmosphere.

Additionally, the breather is outfitted with a resilient nylon standpipe and polypropylene oil mist reducer to allow oil mist to coalesce and drain back into the reservoir, rather than compromising the desiccant. Six high-quality umbrella check-valves are located underneath the unit to isolate equipment from ambient conditions, prolonging breather life and protecting system integrity.

## By the Number

### 1—Six Check-Valves

High-quality umbrella check-valves that won't clog or stick are located underneath the unit for added protection from washdown environments. Check-valves isolate equipment from ambient conditions prolonging breather life, and protecting system integrity.

### 2—Integrated Nylon Standpipe

The integrated standpipe provides excellent vibration resistance and dissipates impact throughout the unit, eliminating weak points. It also allows even airflow distribution throughout the unit, preventing inaccurate readings of desiccant saturation.

### 3—Honeycomb Technology Oil Mist Reducer

The oil mist reducer is situated inside the standpipe, made from polypropylene for maximum chemical compatibility. Mimicking nature's intricate honeycomb design, this feature allows oil mist to coalesce and drain back into the reservoir, rather than compromising the desiccant.

### 4—Resilient Polycarbonate Body

Shock-absorbing, clear casing provides reliable service, easy visual maintenance, and UV resistance.

### 5—Filter Element

Polyester filter element removes airborne contamination to 3-micron absolute. Unique loops allow particles to release during system exhalation, helping to increase breather life.

### 6—Foam Pad

Foam filter captures any oil mist and disperses incoming air evenly over filtration and drying areas.

### 7—Water Vapor Adsorbent

Silica gel adsorbs water from incoming air and can hold up to 40% of its weight. Condition is indicated by change of color from blue to light pink.

### 8—Secondary Filter Element

Second polyester filter element protects against migration of desiccant dust, providing maximum efficiency.

### 9—Threaded Mounting

Internal threads provide durability and stability and can be used with one of several adapters.



# Specs



## Materials & Components

- Filter media: Polyurethane, polyester
- Hydrophilic agent: Silica gel
- All other materials: Polycarbonate, nylon, polypropylene, PVC, Buna-N, silicon, EPDM

## Filter Efficiency

- 3 $\mu$  absolute ( $\beta_{3\mu} \geq 200$ )

## Recommended Temperature Range

- -20°F to 200°F
- -29°C to 93°C

## Chemical Compatibility

*Recommended:*

- All gear oil
- Most hydraulic fluid
- Mineral & synthetic oil

*Not recommended:*

- Hydrogen sulfide
- Sulfuric acid
- Highly alkaline cleaners

## Measurements

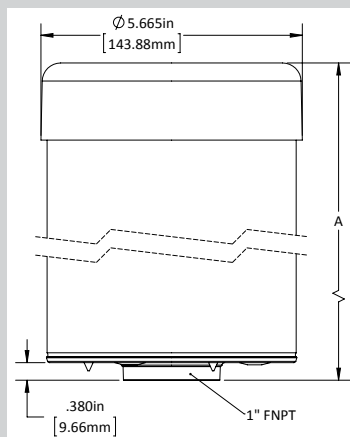

LEXES1F-12	4.7in/119mm
LEXES1F-22	6.4in/163mm
LEXES1F-32	8.2in/208mm
LEXES1F-42	10.0in/254mm

## Sizing Recommendations

Model	Max. Airflow at 1psid	Recommended Max. Volume	
		Gearbox/Storage Tank	Hydraulic Reservoir
LEXES1F-12	27cfm/765lpm	400gal/1514L	100gal/379L
LEXES1F-22	26cfm/736lpm	600gal/2271L	200gal/757L
LEXES1F-32	25cfm/708lpm	800gal/3028L	300gal/1136L
LEXES1F-42	24cfm/680lpm	1000gal/3785L	400gal/1514L

Size	Maximum Water Retention
LEXES1F-12	7.7 fluid oz/228ml
LEXES1F-22	14.1 fluid oz/417ml
LEXES1F-32	20.5 fluid oz/606ml
LEXES1F-42	27.0 fluid oz/798ml

Model	Connection	Amount of Desiccant	Shipping Weight (unit/case)
LEXES1F-12	1" Female (FNPT)	1.2lb/0.54kg	3lbs/18lb 1.36kg/8.16kg
LEXES1F-22	1" Female (FNPT)	2.2lb/1.0kg	4.1lbs/26lb 1.86kg/11.79kg
LEXES1F-32	1" Female (FNPT)	3.2lb/1.45kg	5.5lbs/33lb 2.49kg/14.97kg
LEXES1F-42	1" Female (FNPT)	4.2lb/1.91kg	6.5lbs/40lb 2.95kg/18.14kg

## Airflow

